



VT Oil-Free Range Operators Handbook

Covering Models:-

VT75 / VT75D

VT150 / VT150D

VT200 / VT200D

VT300 / VT300D

VT400 / VT400D

BAMBI AIR COMPRESSORS LTD

152 Thimble Mill Lane
Heartlands
Birmingham
B7 5HT
Tel: 0121 322 2299
Fax: 0121 322 2297

Email: sales@bambi-air.co.uk
www.bambi-air.co.uk

Operating Manual

**Your Bambi Air Compressor is a precision engineered product.
By following these simple steps you will ensure years of trouble free use.**

Parts & Service are available from your Bambi dealer
It is important to quote Model, Type & Serial Number in all communications.
The substitution of parts not manufactured nor approved by Bambi can impair performance, service life and create potential mechanical or personnel hazards and will invalidate your warranty.
Bambi reserves the right to modify the contents of this operating booklet without notice and the information is in no way binding on the company.

Warranty

Provided the operating instructions have been followed and the compressor has been properly maintained Bambi compressors are guaranteed against faulty workmanship for a period of 1 year.
The air receiver is guaranteed for 5 years.
The guarantee does not cover damage by misuse, incorrect parts or service.
Contact Bambi Air Compressors or your retailer for further information.

Safety Precautions

What you **must** do

- Read these instructions before using your air compressor
- Ensure the compressor has been installed, electrically connected and piped in by a properly qualified person.
- Ensure the compressor is kept upright at all times

What you **must not** do

- Do not attempt any maintenance on the compressor until it has been isolated from the power supply
- Do not attempt any work on the compressor until the air receiver and pipe work systems are depressurised.
- Compressed air is dangerous if misused and can prove fatal. Avoid any bodily contact with compressed air
- During operation the motor will become quite hot to the touch. Avoid contact to prevent burns.
- Never tamper with the pressure relief valve
- Never lubricate the oil free motor or pump assembly, this will cause severe damage.
- Never obstruct cooling fans or outlet vents

Siting The Compressor

What you **must** do

- Provide adequate protection from the weather
- Site the compressor level in both plains
- Larger models are heavy, ensure the surface has sufficient load bearing capacity
- Allow access for maintenance all around the compressor
- Site in a dry area, avoiding damp or humid conditions. The site must be dust free, well ventilated and have a cool ambient temperature. 40 C should be regarded as the maximum allowable ambient

What you **must not** do

- Enclose the compressor or allow hot air generated by the motor to re-circulate around the compressor. Ensure there is 30cm clearance around the compressor
- Restrict air flow around the after cooler or after cooler fan unit

Electrical Connections

Where applicable, compressors are supplied with a moulded plug in accordance with national standards.

Never remove the moulded plug.

Note !

Duplex models VT300/300D, VT400/400D must be connected to a dedicated fused 20 amp supply.

Wired in accordance with European Standard –

Blue = neutral Brown = live Yellow & Green Stripe = earth

Operation

Refer to exploded parts diagrams and illustrations when reading this section.

Starting & Stopping

Plug the compressor into an outlet socket of nominal voltage and fitted with the correct fuse as shown in section Electrical Connections.

Switch the compressor on using the O/I switch located on the pressure switch - see *figs 1&2*.

The compressor will start running and automatically switch off at the preset pressure.

Note !

Duplex models VT300/300D, VT400/400D are fitted with a sequential start system to reduce electrical loading.

You will notice one motor starting a few seconds after the other. This is normal.

As air is used the pressure drops and the motor will restart at the preset pressure. Approx 2 Bar differential.

Note !

Each time the compressor switches off or the power supply is interrupted, you will hear a short hiss of air.

You are hearing the unloader valve discharging the residual delivery pipe pressure. This is normal.

Operation – Dryer Models

When equipped with an air dryer unit, the compressor will automatically dry the compressed air before it is stored in the air receiver. This happens automatically and requires no additional maintenance.

This eliminates the need to manually drain the air receiver.

Operation is similar to standard versions with the following change :-

Each time the compressor switches off or the power supply is interrupted, the dryer purge valve opens and automatically activates the drain valve on the after cooler filter allowing the dryer tower to regenerate. All accumulated moisture will discharge into the condensate tank. This should be emptied when it reaches $\frac{3}{4}$ full.

See *fig 6*.

Note !

Waste condensate must be handled in accordance with national environmental rules.

Do not exceed the recommended 50% duty cycle, otherwise the dryer will not activate and the humidity of the air will increase.

Ensure the after cooler fins are kept clean of accumulated dust.

Adjusting Outlet Pressure

Use the pressure regulator to adjust the outlet pressure. The 40mm pressure gauge indicates the selected pressure. To increase line pressure rotate the black knob on top of the filter regulator in a clockwise manner, to decrease turn anti clockwise. It is possible to lock the setting by pushing the knob down until it “clicks” home – see *fig 3*.

Routine Maintenance

Draining the Air Receiver

Drain condensate from air receiver at a pressure of no more than 2 Bar. Slowly open the drain tap provided to allow water to flow out – see *fig 4*. Close drain tap when all water has drained off.

Automatic drains where fitted do not require draining, however the condensate tank will require emptying
– see *previous section “Operation Dryer Models”*.

Check Pressure Relief Valve

Ensure the air receiver is not pressurised. Unscrew the knurled end of the pressure relief valve until an audible “click” is heard. Retighten without using excessive force - see *fig 5*.

Technical

We recommend the compressor has a maximum 50% duty cycle to prolong pump life. The motor must never be allowed to run continuously otherwise it will overheat and may become damaged

Do not ignore air leaks. All air connections must be leak free to prevent the compressor from over heating.

The compressor is fitted with a thermal overload. In the event of excessive temperature the motor will switch off. To re-set the overload follow the procedure below :-

Models VT75/75D, VT150/150D, VT200/200D

Motor Sizes 0.75Hp, 1.5Hp, 2.0Hp
Switch off at the pressure switch.
Allow 50 minutes for the motor to cool down.
Switch on at the pressure switch.

Models VT300/300D, VT400/400D

Motor Size 2x1.5Hp – 2x2.0Hp
The re-set is integral with the pressure switch.
The pressure switch will automatically turn off (O) in the event of motor overload.
Turn the pressure switch to the on position (I).

You must find the cause of the overload and rectify this before continuing to use the compressor.

Check for -

- Drain tap not closed properly
- Air leaks on the pneumatic fittings
- Compressor not the correct size for the work load

If problems persist contact your dealer.

Preventative Maintenance

Operation	Daily	Weekly	Annually	2 Years	5 Years
Drain Air Receiver < 24 Litres	•				
Drain Air Receiver > 50 Litres		•			
Replace Air Intake Filter			•		
Check Pressure Relief Activation			•		
Clean After Cooler Fins			•		
Check Piston Ring				•	
Replace Air Dryer Filter					•
Desiccant Change					•

Above are to be considered minimum frequency

Technical Specification

VT 0.75Hp Pump Specification

Motor Kw / Hp	0.55 / 0.75
---------------	-------------

Voltage	220/240
---------	---------

Frequency Hz	50
--------------	----

Amps	3.9
------	-----

Displacement l/min	120
--------------------	-----

VT 1.50Hp Pump Specification

Motor Kw / Hp	1.1 / 1.5
---------------	-----------

Voltage	220/240
---------	---------

Frequency Hz	50
--------------	----

Amps	6.8
------	-----

Displacement l/min	175
--------------------	-----

VT 2.0Hp Pump Specification

Motor Kw / Hp	1.5 / 2.0
---------------	-----------

Voltage	220/240
---------	---------

Frequency Hz	50
--------------	----

Amps	8.6
------	-----

Displacement l/min	220
--------------------	-----

VT75

Ref No.	Description	Part no.
1	Rubber foot	BPB0601
2	Inspection plug	BPB0243
3	Inspection plug seal	BPB0502
4	24 litre tank	BPB0260
5	40mm rubber mounting	BPB0272
6	Motor mounting bracket	BPB0321
7	Solenoid c/w cable	BPB0545
8	1/8 x 6mm push fitting	BPB0711
9	6mm black nylon tube	BPB0203
10	Crankcase mounting bracket	BPB0347
11	20mm rubber mounting	BPB0273
12	Drain valve tap	BPB0281
13	3/8 x 10mm tube elbow	BPB0280
14	Red nylon drain tube	BPB0284
15	50mm tank pressure gauge	BPB0658

Ref No.	Description	Part no.
16	Pressure switch	BPB0550
17	40mm line pressure gauge	BPB0657
18	Pressure regulator	BPB0510
19	1/4 x 1/4 male adaptor	BPB1078
20	1/4 on-off tap	BPB1079
21	Safety valve	BPB1084
22	1/4 male/female elbow	BPB1139
23	3/8 male adaptor	BPB0283
24	Delivery pipe	BPB0508
25	1/8 x 6mm elbow bush fitting	BPB0044
26	3/8 male - female elbow	BPB0282
27	Non-return valve	BPB0656
28		
29		
30		

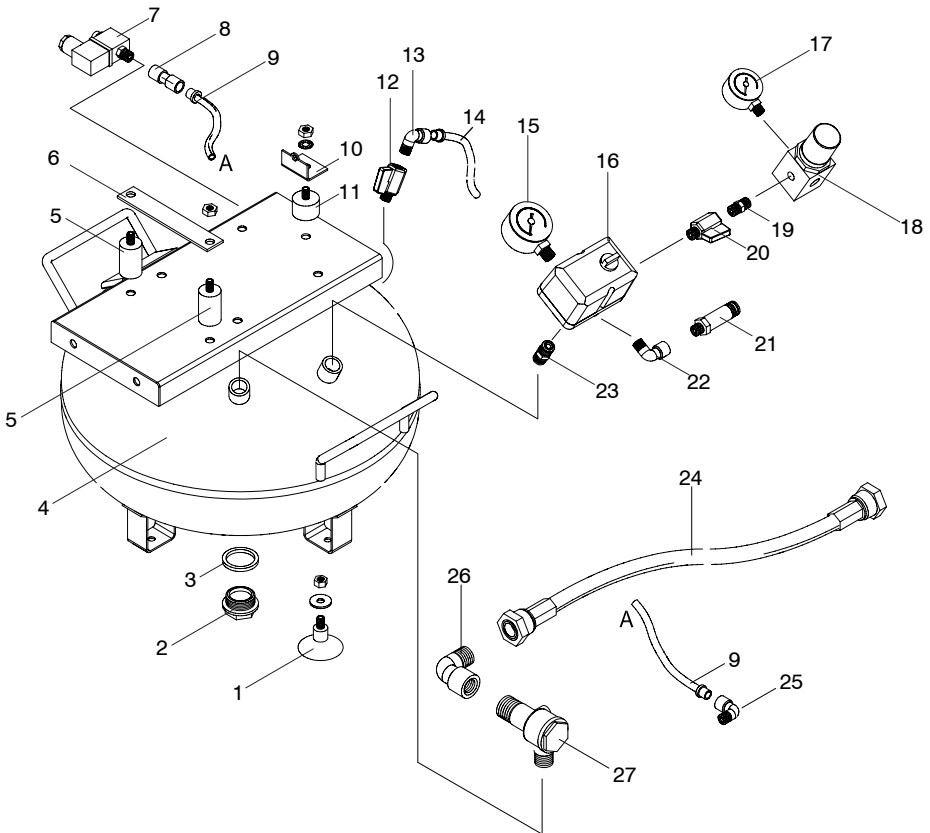

VT75D

Ref No.	Description	Part no.
1	Condensate diffuser	BPB0588
2	1/8 x 6mm push tube fitting	BPB0154
3	Condensate bottle - complete	BPB0058
4	1.3m 6mm nylon tube	BPB0203
5	6mm tube divider	BPB0279
6	1/8 x 6mm elbow tube fitting	BPB0044
7	Solenoid valve c/w cable	BPB0545
8	Dryer assembly	BPB0548
9	1/4 x 10mm push tube fitting	BPB0552
10	0.65m 10mm black nylon tube	BPB0551
11	3/8 x 10mm tube swivel elbow	BPB0277
12	Coalescing filter	BPB0258
13	Coalescing filter element	BPB0655
14	3/8 male/female elbow	BPB0282
15	Aftercooler - complete	BPB0560
16	Aftercooler mounting bracket	BPB0558
17	40mm mounting rubber	BPB0272
18	Motor mounting bracket	BPB0321
19	Crankcase mounting bracket	BPB0347
20	20mm mounting rubber	BPB0273
21	Drain valve tap	BPB0281
22	Red nylon drain tube	BPB0284

Ref No.	Description	Part no.
23	3/8 x 10mm tube stud elbow	BPB0280
24	3/8 male adaptor	BPB0283
25	50mm tank pressure gauge	BPB0658
26	Pressure switch	BPB0550
27	1/4 On-off tap/Closing ring	BPB1079
28	40mm line pressure gauge	BPB0657
29	Pressure regulator	BPB0510
30	1/4 male adaptor	BPB1078
31	Safety valve	BPB1084
32	1/4 male/female elbow	BPB1139
33	Non-return valve	BPB0656
34	3/8 x 10mm straight tube conn.	BPB0275
35	Rubber foot	BPB0601
36	Inspection plug	BPB0243
37	Inspection plug seal	BPB0502
38	24 litre tank	BPB0260
39	1/4 x 10mm Tube swivel elbow	BPB0276
40	Dryer mounting clamp	BPB0503
41	Purge tank bleed pipe	BPB0285
42	Delivery pipe	BPB0508
43	Purge tank	BPB0404

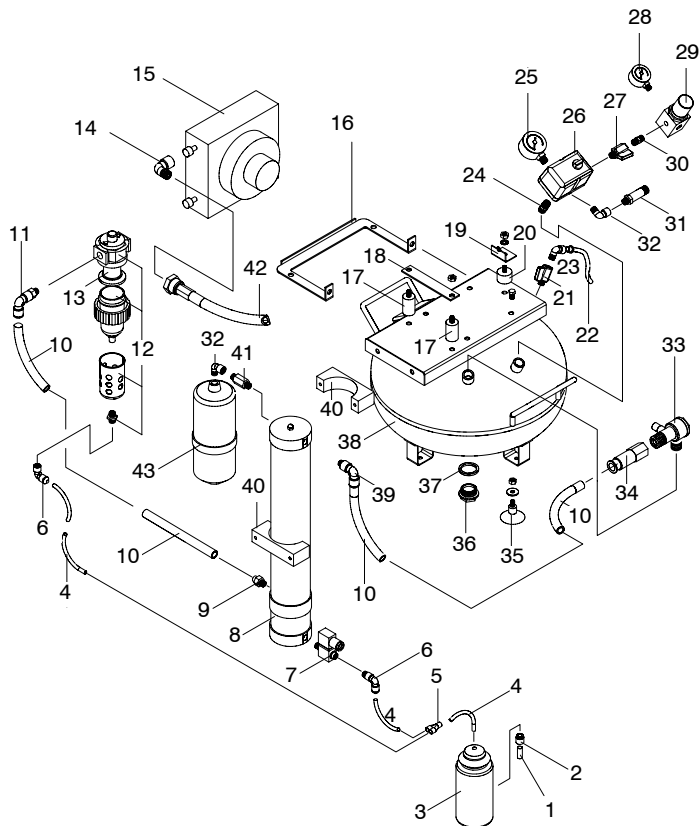

VT150 / VT200

Ref No.	Description	Part no.
1	Rubber foot	BPB0601
2	Inspection plug	BPB0243
3	Inspection plug seal	BPB0502
4	50 litre tank	BPB0261
5	40mm mounting rubber	BPB0272
6	Motor mounting bracket [VT150]	BPB0321
6	Motor mounting bracket [VT200]	BPB0516
7	Solenoid valve c/w cable	BPB0545
8	1/8 x 6mm push fitting	BPB0711
9	0.4m 6mm nylon tubing	BPB0203
10	20mm mounting rubber	BPB0273
11	Crankcase mounting bracket [VT150]	BPB0347
11	Crankcase mounting bracket [VT200]	BPB0517
12	3/8 drain tap	BPB0281
13	3/8 x 10mm tube elbow	BPB0280
14	0.6m drain tube	BPB0284

Ref No.	Description	Part no.
15	50mm tank pressure gauge	BPB0658
16	Pressure switch	BPB0550
17	40mm line pressure gauge	BPB0657
18	Pressure regulator	BPB0510
19	1/4 Male adaptor	BPB1078
20	On-off tap	BPB1079
21	Safety valve	BPB1084
22	1/4 Male/female elbow	BPB1139
23	3/8 Male adaptor	BPB0283
24	400mm Delivery pipe	BPB0508
25	1/8 x 6mm elbow tube fitting	BPB0044
26	3/8 Male/female elbow	BPB0282
27	Non-return valve	BPB0656

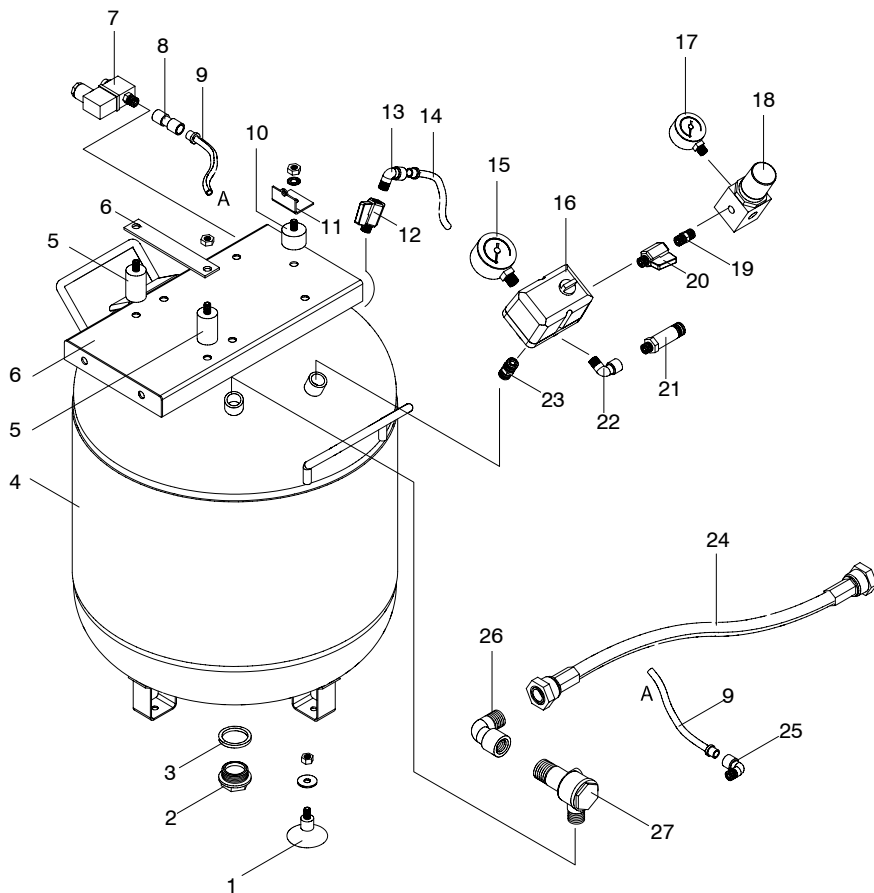

VT150D / VT200D

Ref No.	Description	Part no.
1	Condensate diffuser	BPB0588
2	1/8 x 6mm Push fitting	BPB0154
3	Condensate bottle complete	BPB0088
4	1.1m 6mm nylon tube	BPB0203
5	6mm Divider	BPB0279
6	1/8 x 6mm Elbow tube fitting	BPB0044
7	Solenoid valve c/w cable	BPB0545
8	Coalescing filter	BPB0258
9	Coalescing filter element	BPB0655
10	1/4 x 3/8 adaptor	BPB0591
11	3/8 x 10mm Tube connector	BPB0592
12	0.65m 10mm Nylon tube	BPB0551
13	3/8 x 10mm Swivel elbow	BPB0593
14	3/8 Male/female elbow	BPB0282
15	Aftercooler	BPB0561
16	Aftercooler bracket	BPB0557
17	40mm Rubber mounting	BPB0272
18	Motor mounting bracket [VT150D]	BPB0321
18	Motor mounting bracket [VT200D]	BPB0516
19	Crankcase mounting bracket [VT150D]	BPB0307
19	Crankcase mounting bracket [VT200D]	BPB0517
20	20mm Rubber mounting	BPB0273
21	3/8 Drain tap	BPB0281

Ref No.	Description	Part no.
22	0.6m 10mm Drain tube	BPB0284
23	3/8 x 10mm Elbow	BPB0280
24	3/8 Male adaptor	BPB0283
25	50mm Tank pressure gauge	BPB0658
26	Pressure switch	BPB0550
27	40mm Line pressure gauge	BPB0657
28	Pressure regulator	BPB0510
29	1/4 Male adaptor	BPB1078
30	On/off tap	BPB1079
31	Safety valve	BPB1084
32	1/4 Male/female elbow	BPB1139
33	Non-return valve	BPB0656
34	50 Litre tank	BPB0261
35	3/8 x 10mm Connector	BPB0275
36	Rubber foot	BPB0601
37	Inspection plug	BPB0243
38	Inspection plug seal	BPB0502
39	1/4 x 10mm Swivel elbow	BPB0276
40	Dryer mounting bracket	BPB0503
41	Dryer assembly	BPB0548
42	400mm Delivery pipe	BPB0508
43	Purge tank bleed valve	BPB0285
44	Purge tank	BPB0484

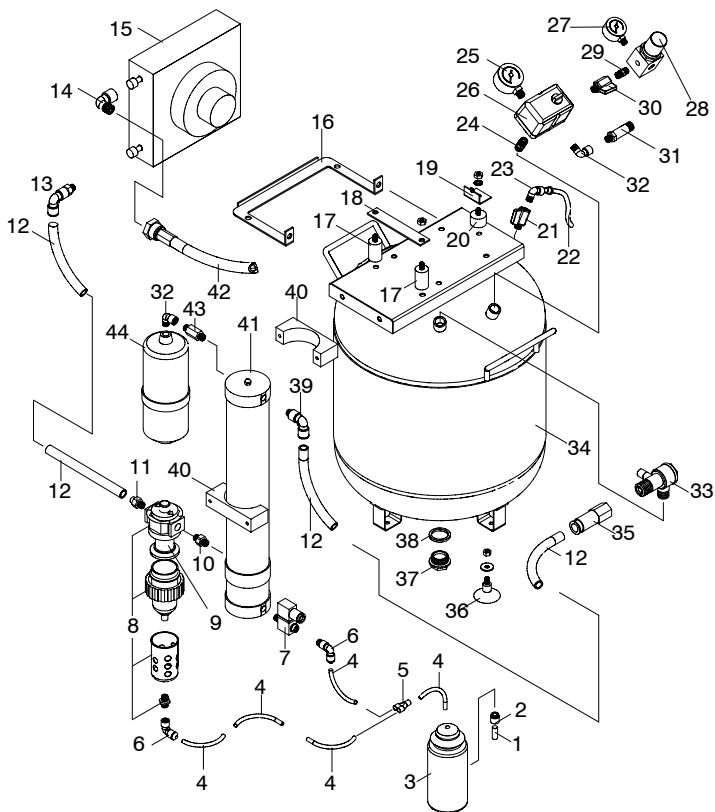

VT300 / VT400

Ref No.	Description	Part no.
1	Inspection plug seal	BPB0502
2	Inspection plug	BPB0243
3	100 Litre tank	BPB0262
4	Rubber foot	BPB0605
5	3/8 Male adaptor	BPB0283
6	1/4 Male/female elbow	BPB1139
7	Safety valve	BPB1084
8	Tank pressure gauge	BPB0658
9	Pressure switch	BPB0549
10	3/8 On/off tap	ATP661
11	Regulator	BPB0511
12	Line pressure gauge	BPB0657
13	3/8 Male/female elbow	BPB0282
14	Drain tube	BPB0199
15	3/8 x 1/4 Hose tail	BPB0652

Ref No.	Description	Part no.
16	Drain valve	BPB0281
17	Solenoid c/w cable	BPB0545
18	1/8 x 6mm Push fitting	BPB0711
19	Crankcase mounting bracket [VT300]	BPB0347
19	Crankcase mounting bracket [VT400]	BPB0517
20	20mm Rubber mounting	BPB0273
21	40mm Rubber mounting	BPB0272
22	Motor mounting bracket [VT300]	BPB0321
22	Motor mounting bracket [VT400]	BPB0516
23	Electrics enclosure	BPB0513
24	Sequential timer	BPB0512
25	6mm Nylon tube	BPB0203
26	1/8 x 6mm Elbow push fitting	BPB0044
27	Delivery hose	BPB0508
28	Non return valve	BPB0656

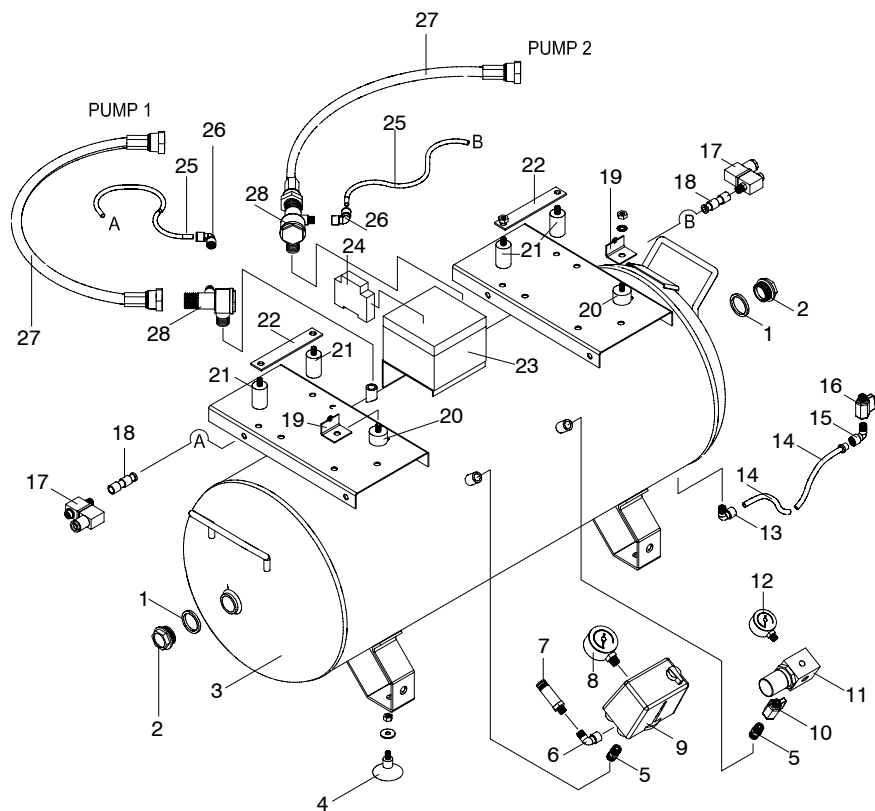

VT300D / VT400D

Ref No.	Description	Part no.
1	Aftercooler mounting bracket	BPB0557
2	Inspection plug	BPB0243
3	Inspection plug seal	BPB0502
4	Rubber foot	BPB0605
5	3/8 Male adaptor	BPB0283
6	1/4 Male elbow	BPB1139
7	Safety valve	BPB1084
8	50mm Tank pressure gauge	BPB0658
9	Pressure switch	BPB0549
10	3/8 on/off tap	ATP661
11	Pressure regulator	BPB0551
12	40mm Line pressure gauge	BPB0657
13	3/8 Male/female elbow	BPB0282
14	3/8 x 1/4 Hose tail	BPB0652
15	Drain tube	BPB0199
16	Drain tube clamp	BPB0119
17	Drain valve	BPB0281
18	1.25m x 10mm Tube	BPB0551
19	Aftercooler	BPB0561
20	3/8 x 10mm Swivel elbow	BPB0593
21	Delivery tube	BPB0508
22	1m 6mm Nylon tube	BPB0203
23	6mm Tube divider	BPB0279
24	1/8 x 6mm Elbow	BPB0044

Ref No.	Description	Part no.
25	Coalescing filter	BPB0044
26	Coalescing filter element	BPB0655
27	3/8 x 10mm Connector	BPB0592
28	1/4 x 3/8 Adaptor	BPB0591
29	Dryer mounting clamp	BPB0503
30	Purge tank	BPB0484
31	Purge tank bleed pipe	BPB0285
32	Dryer assembly	BPB0548
33	1/4 x 10mm Swivel elbow	BPB0276
34	Solenoid valve c/w cable	BPB0545
35	3/8 x 10mm Connector	BPB0275
36	Non return valve	BPB0656
37	1/8 x 6mm Push fitting	BPB0154
38	Condensate diffuser	BPB0588
39	Condensate bottle	BPB0587
40	Motor mounting bracket [VT300D]	BPB0321
40	Motor mounting bracket [VT400D]	BPB0516
41	40mm Rubber mounting	BPB0272
42	Crankcase mounting bracket [VT300D]	BPB0347
42	Crankcase mounting bracket [VT400D]	BPB0517
43	20mm Rubber mounting	BPB0273
44	Electrics enclosure	BPB0513
45	Sequential timer	BPB0512
46	100 Litre tank	

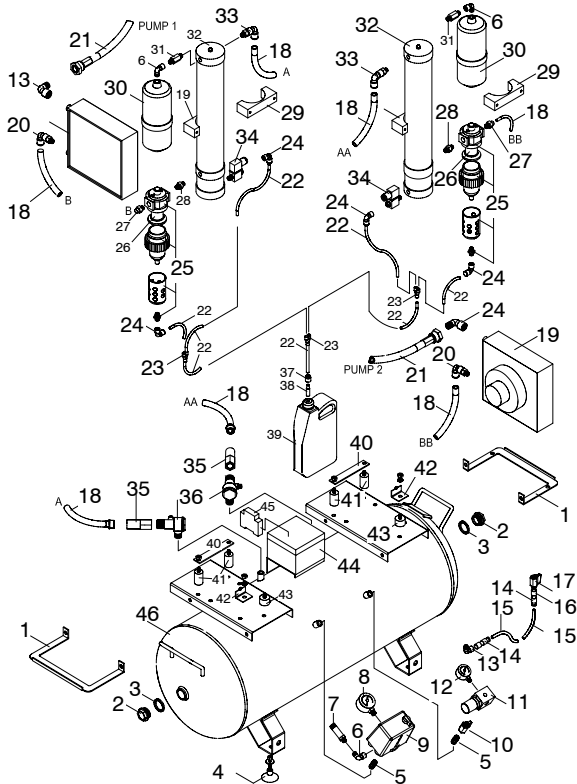

Motor / Pump Parts: VT75 / VT75D / VT150 / VT150D / VT300/VT300D

Ref No.	Description	Part no.
1a	Motor VT75	BPB0663
1b	Motor VT150	BPB0664
2	3/8 Elbow	BPB0629
3	Block fixing	BPB0665
4	Block motor side	BPB0666
5	Block screw	BPB0667
6	Block bearing	BPB0668
7	Short spacer	BPB0669
8	Con rod	BPB0670
9	Con rod bearing	BPB0671
10	Eccentric	BPB0672
11	Large spacer	BPB0673
12	Block "O" ring	BPB0674
13	Block fan side	BPB0675
14	Stud bolt	BPB0676
15	16mm washer	BPB0677
16	M16 Nut	BPB0678
17	Fan	BPB0625
18	M16 Fan nut	BPB0679
19	Fan cowlng	BPB0626
20	Cylinder head bolt	BPB0680

Ref No.	Description	Part no.
21	Cylinder head	BPB0681
22	Intake filter	BPB0682
23	Cylinder head gasket	BPB0620
24	Valve plate nut	BPB0683
25	Valve plate washer	BPB0684
26	Outlet valve strip	BPB0685
27	Valve plate	BPB0686
28	Inlet valve strip	BPB0685
29	Valve strip bolt	BPB0687
30	Valve plate gasket	BPB0621
31	Cylinder bolt	BPB0688
32a	Cylinder VT75	BPB0689
32b	Cylinder VT150	BPB0690
33	Cylinder "O" ring	BPB0691
34	Top washer bolt	BPB0692
35	Top washer	BPB0693
36	Piston seal	BPB0694
37a	Capacitor VT75	BPB0695
37b	Capacitor VT150	BPB0696

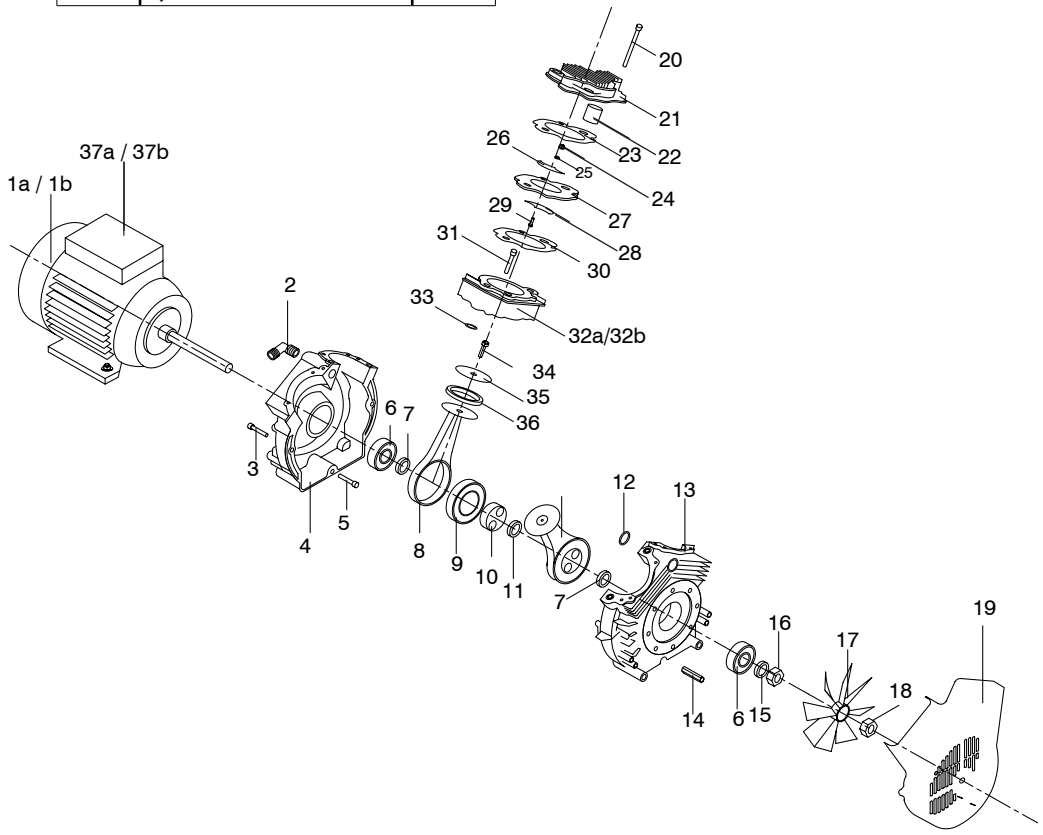

Motor / Pump Parts: VT200 / VT200D / VT400 / VT400D

Ref No.	Description	Part no.
1	Motor VT200	BPB0697
2	3/8 Elbow	BPB0698
3	Block fixing	BPB0665
4	VT200 Block motor side	BPB0699
5	Block screw	BPB0667
6	Block bearing	BPB0668
7	Short spacer	BPB0669
8	VT200 Con rod	BPB0700
9	Con rod bearing	BPB0671
10	Eccentric	BPB0672
11	Large spacer	BPB0673
12	VT200 Capacitor	BPB0701
13	Block "O" ring	BPB0674
14	VT200 Block fan side	BPB0702
15	Stud bolt	BPB0676
16	16mm washer	BPB0677
17	M16 Nut	BPB0678
18	Inner fan cover	BPB0703
19	Fan	BPB0704
20	M16 Fan nut	BPB0679

Ref No.	Description	Part no.
21	Fan ring	BPB0705
22	Fan cover fixing	BPB0706
23	Cylinder head bolt	BPB0680
24	Cylinder head	BPB0681
25	Intake filter	BPB0682
26	Cylinder head gasket	BPB0620
27	Valve plate nut	BPB0683
28	Valve plate washer	BPB0684
29	Outlet valve strip	BPB0685
30	Valve plate	BPB0686
31	Inlet valve strip	BPB0685
32	Valve strip bolt	BPB0687
33	Valve plate gasket	BPB0707
34	Cylinder bolt	BPB0688
35	Cylinder VT200	BPB0708
36	Cylinder "O" ring	BPB0691
37	Top washer bolt	BPB0692
38	Top washer	BPB0709
39	Piston seal	BPB0710
40	Outer fan cover	BPB0716

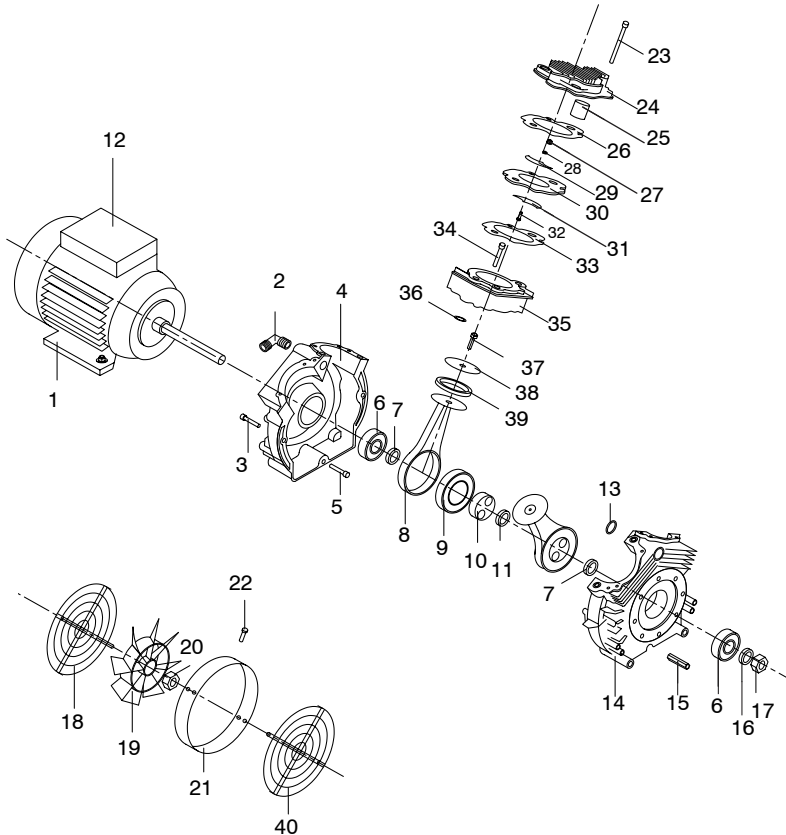
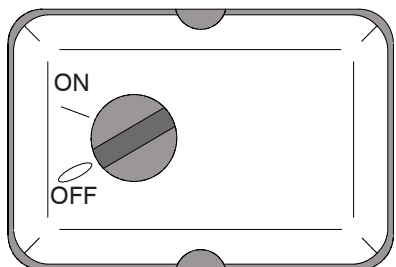
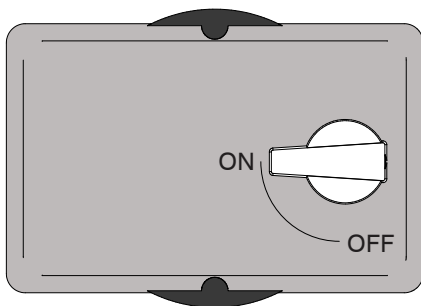

Fig 1



VT75 & 75D
VT150 & 150D
VT200 & 200D

WW



VT300 & 300D
VT400 & 400D

Fig 3

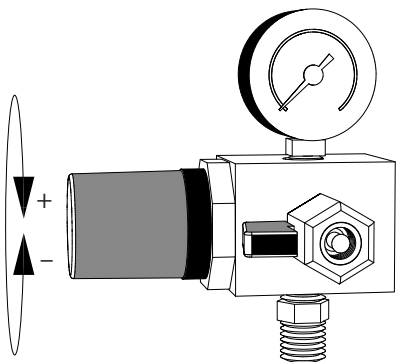

Fig 4

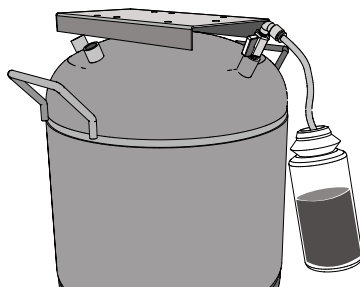

Fig 5

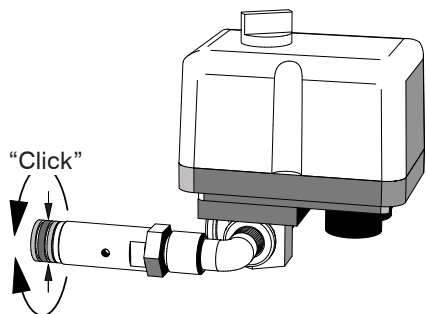
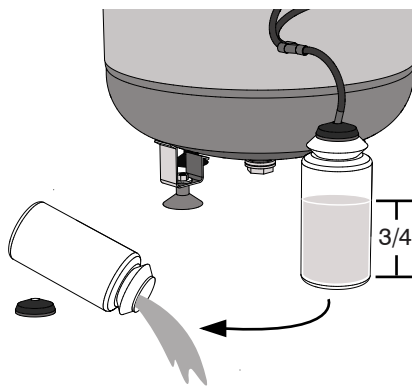
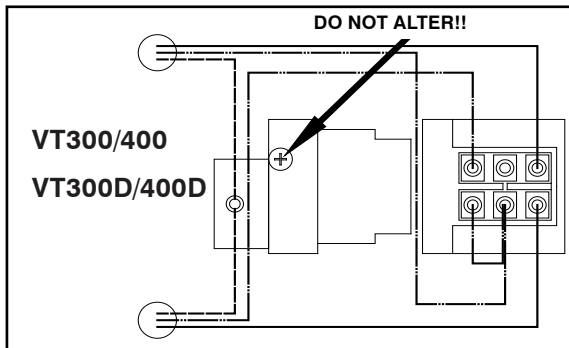
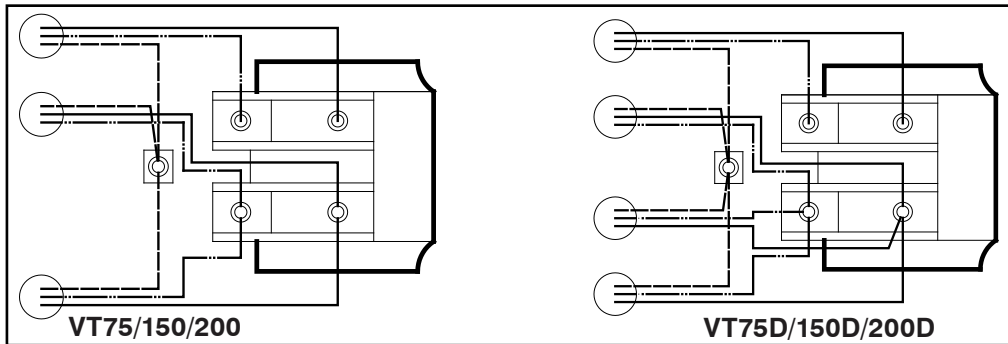

Fig 6





KEY:

- Live
- Neutral
- Earth

