



Budget Range Operators Handbook

BAMBI AIR COMPRESSORS LTD

152 Thimble Mill Lane
Heartlands
Birmingham
B7 5HT
United Kingdom
Tel: 0121 322 2299
Fax: 0121 322 2297

Email: sales@bambi-air.co.uk
www.bambi-air.co.uk

Operating Manual

Your Bambi Air Compressor is a precision engineered product. By following these simple steps you will ensure years of trouble free use.

Parts & Service are available from your Bambi dealer.

It is important to quote Model, Type & Serial Number in all communications.

The substitution of parts not manufactured nor approved by Bambi can impair performance, service life and create potential mechanical or personnel hazards and will invalidate your warranty.

Bambi reserves the right to modify the contents of this operating booklet without notice and the information is in no way binding on the company.

Warranty

Provided the operating instructions have been followed and the compressor has been properly maintained, Bambi compressors are guaranteed against faulty workmanship for a period of 1 year.

The air receiver is guaranteed for 3 years.

The guarantee does not cover damage by misuse, incorrect parts or service.

Contact Bambi Air Compressors or your retailer for further information.

Safety Precautions

What you **must** do:

- Read these instructions before using your air compressor
- Ensure the compressor has been installed, electrically connected and piped in by a properly qualified person
- Ensure the compressor is kept upright at all times

What you **must not** do:

- Do not attempt any maintenance on the compressor until it has been isolated from the power supply
- Do not attempt any work on the compressor until the air receiver and pipe work systems are depressurised.
- Compressed air is dangerous if misused and can prove fatal. Avoid any bodily contact with compressed air
- During operation the motor will become quite hot to the touch. Avoid contact to prevent burns. At no time must the oil temperature be allowed to exceed 100°C
- Never tamper with the pressure relief valve
- Never change the oil when the compressor is still warm. Take necessary precautions to avoid contact with the skin

Bambi SB42/46 compressor oil does not contain hazardous components and is not required to be labelled dangerous according to the Classification, Packaging and Labelling of dangerous substances regulation (CPL) Regulation 1984.

Siting The Compressor

What you **must** do:

- Provide adequate protection from the weather
- Site the compressor level in both plains
- Larger models are heavy, ensure the surface has sufficient load bearing capacity
- Allow access for maintenance all around the compressor
- Site in a dry area, avoiding damp or humid conditions. The site must be dust free, well ventilated and have a cool ambient temperature. 35°C should be regarded as the maximum allowable ambient

What you **must not** do:

- Enclose the compressor or allow hot air generated by the motor to re-circulate around the compressor

Electrical Connections

All 220/240 volt compressors are supplied with a moulded plug in accordance with national standards. Never remove the moulded plug.

Wired in accordance with European Standard –

Blue = neutral Brown = live Yellow & Green Stripe = earth

Operation

Refer to exploded parts diagrams and illustrations when reading this section.

Oil Level

Your Bambi compressor is shipped without oil for transit. Before use, you must fill the motor to the correct level.

- Remove oil filler plug - see *fig 1*
- Pour oil in to motor until the correct level is reached indicated on the oil sight glass, approx 500cc - see *fig 2*
- Refit the oil filler plug but do not over tighten

Always use Bambi SB42/46 compressor oil. Failure to do so will invalidate your warranty.

Starting & Stopping

Plug the compressor into an outlet socket of nominal voltage and fitted with a 13 amp fuse.

Switch the compressor on using the on/off control on top of the pressure switch. - see fig 3

The compressor will start running and automatically switch off at the preset pressure.

As air is used, the pressure drops and the motor will restart at the preset pressure. Approx 2 Bar differential.

Note!

Never tamper with the pressure switch settings; these are factory set.

Adjusting Outlet Pressure

Use the filter regulator to adjust the outlet pressure. The 40mm pressure indicates the selected pressure. To increase line pressure, rotate the black knob on top of the filter regulator in a clockwise manner; to decrease turn anti clockwise. It is possible to lock the setting by pushing the knob down until it "clicks" home – see fig 4

Routine Maintenance

Draining the Air Receiver

Drain condensate from air receiver at a pressure of no more than 2 Bar.

Slowly open the drain tap provided to allow water to flow out – see figs 7 & 8

Close drain tap when all water has drained off.

Do not overtighten; this will damage the tap seal.

Automatic drains where fitted do not require draining, however the drain bottle will require emptying.

Draining the Filter/Regulator Unit

Slowly open the drain screw provided to allow water to flow out.

Close drain screw when all water has drained off - see fig 5

Note !

Waste condensate must be handled in accordance with national environmental rules.

Check Pressure Relief Valve

Ensure the air receiver is not pressurised. Unscrew the knurled end of the pressure relief valve until an audible "click" is heard. Retighten without using excessive force – see fig 6

Technical

The compressor has a maximum 50% duty cycle. The motor must never be allowed to run continuously; otherwise it will overheat and may become damaged.

Do not ignore air leaks. All air connections must be leak free to prevent the compressor from over heating.

The compressor is fitted with a thermal overload. In the event of excessive temperature, the motor will switch off. After about 50 minutes when the motor has cooled, it will automatically reset.

Note!

You must find the cause of the overload and rectify this before continuing to use the compressor.

Check for -

- Drain tap not closed properly
- Air leaks on the pneumatic fittings
- Compressor not the correct size for the work load

Preventative Maintenance

Operation	Daily	Weekly	Monthly	Annually
Drain Air Receiver < 15 Litres	•			
Drain Air Receiver > 15 Litres		•		
Drain Filter Regulator			•	
Check Oil Level		•		
Change Oil				•
Replace Air Intake Filter				•
Replace Filter Regulator Element				•
Check Pressure Relief Valve Activation				•

Above are to be considered minimum frequency

Pump Diagram

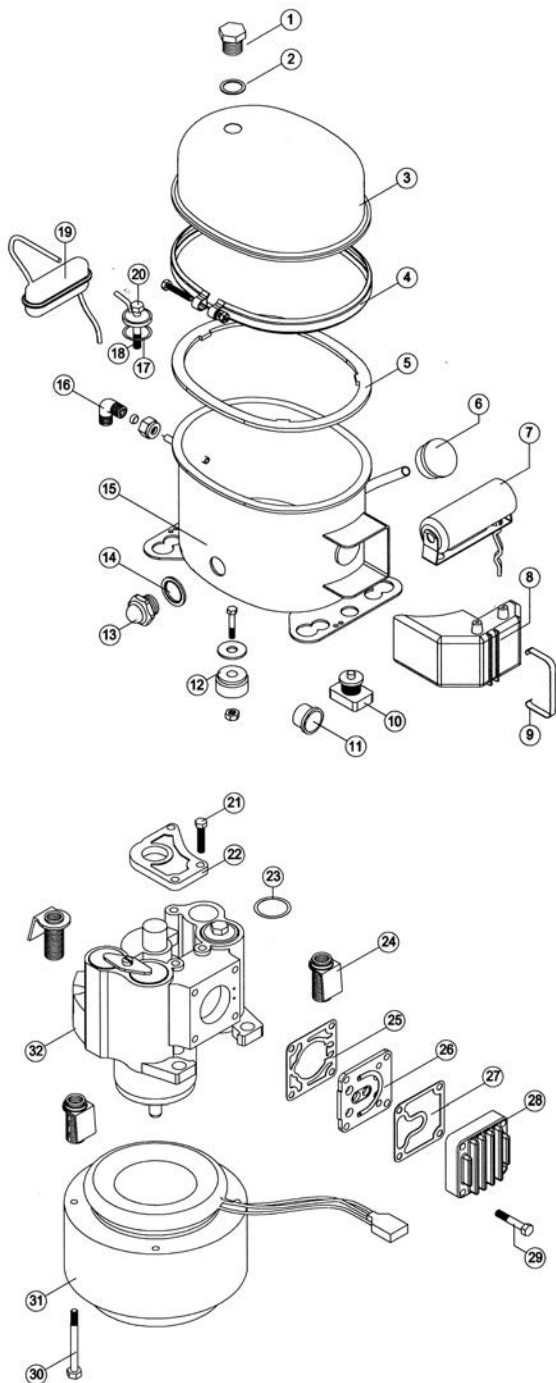

Ref No.	Description	BPB	Part no.
1	Oil filler plug	BPB	0079
2	Oil filler plug seal	BPB	0098
3	Top casing	BPB	1058
4	Closing ring	BPB	1059
5	Sealing gasket	BPB	1057
6	Air intake filter	BPB	1003
7	Capacitor - 220/240v	BPB	1051
7	Capacitor - 110v	BPB	0137
8	Terminal box cover	BPB	1047
9	Terminal box cover clip	BPB	1048
10	Start relay - 220/240v	BPB	1053
10	Start relay 110v	BPB	0138
11	Overload 220/240v	BPB	1052
11	Overload - 110v	BPB	0139
12	Mounting set (4)	BPB	1055
13	Sight glass	BPB	1009
14	Sight glass seal	BPB	1010
15	Bottom casing	BPB	1056
16	Outlet elbow	BPB	0065
17	Delivery pipe gasket	BPB	1042
18	Delivery bolt	BPB	1039
19	Delivery pipe	BPB	1041
20	Sealing ring bolt/nut	BPB	1060
21	Bearing bolt (3)	BPB	1028
22	Bearing	BPB	1029
23	Gasket	BPB	1044
24	Mounting spring (3)	BPB	1038
25	Valve plate gasket	BPB	1033
26	Valve plate	BPB	1034
27	Cylinder head gasket	BPB	1035
28	Cylinder head	BPB	1036
29	Cylinder head bolt (4)	BPB	1037
30	Stator bolt (4)	BPB	1032
31	Stator - 220/240v	BPB	1031
31	Stator - 110v	BPB	0334
32	Motor block	BPB	1030

Unit Diagrams

BB8 / BB15V

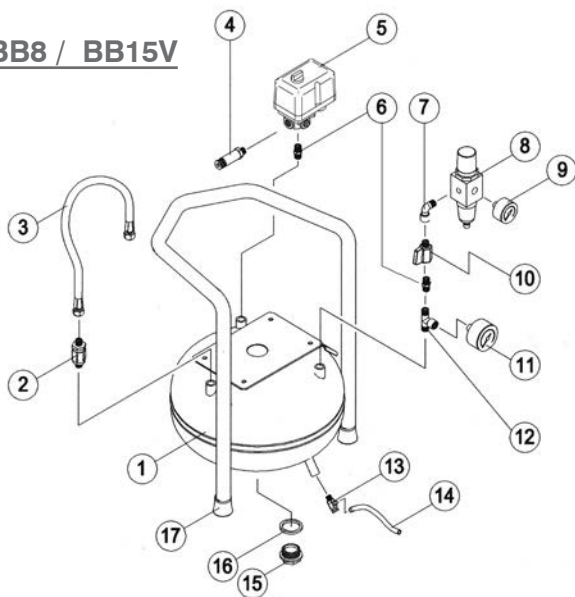

Ref No.	Description BB8/BB15V		Part no.
1	Air receiver - 8 / 15 litre	BPB	0468 / 0470
2	Non return valve	BPB	1086
3	Delivery hose - 200mm	BPB	1102
4	Relief valve	BPB	1084
5	Pressure switch	BPB	1074
6	1/4 x 1/4 connector	BPB	1078
7	1/4 MF elbow	BPB	1139
8	Filter regulator unit	BPB	1080
9	40mm pressure gauge	BPB	1077
10	On/off valve	BPB	1079
11	50mm pressure gauge	BPB	1081
12	1/4 MFF Tee	BPB	1109
13	Drain tap	BPB	1138
14	Drain tap tube & clamp	BPB	1138
15	Inspection plug	BPB	0243
16	Inspection plug seal	BPB	0502
17	Rubber foot	BPB	0247

BB15

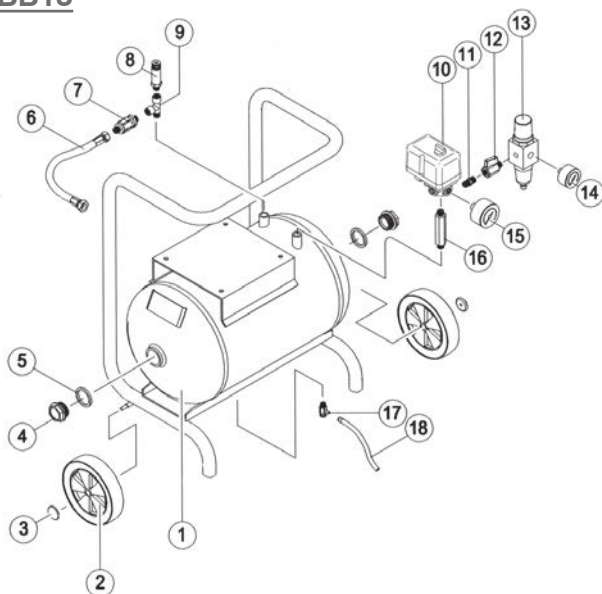

Ref No.	Description		Part no.
1	Air receiver - 15 litre	BPB	0469
2	Wheel	BPB	1144
3	Wheel cap	BPB	1108
4	Inspection plug	BPB	0243
5	Inspection plug seal	BPB	0502
6	Delivery hose - 300mm	BPB	1087
7	Non return valve	BPB	1086
8	Relief valve	BPB	1084
9	1/4 MFF tee	BPB	1109
10	Pressure switch	BPB	1074
11	1/4 x 1/4 connector	BPB	1078
12	On/off valve	BPB	1079
13	Filter regulator unit	BPB	1080
14	40mm pressure gauge	BPB	1077
15	50mm pressure gauge	BPB	1081
16	1/4 extension piece	BPB	0152
17	Drain tap	BPB	1138
18	Drain tap tube & clamp	BPB	1138

On auto drain machines the pressure switch part number is BPB0550 and the unloader valve is part number BPB1205.

BB24

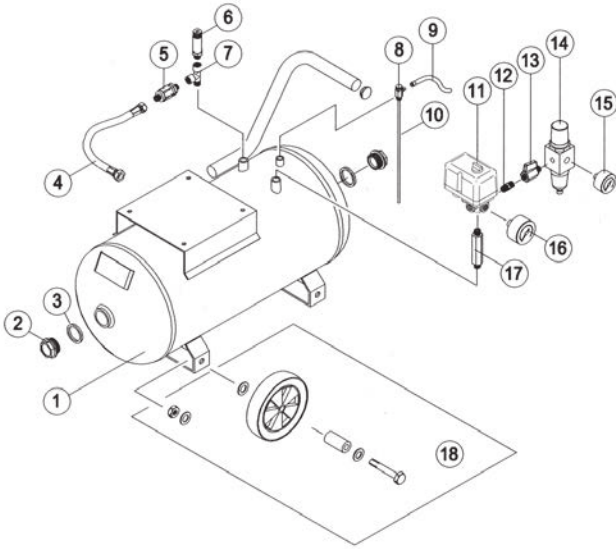

Ref No.	Description		Part no.
1	Air receiver - 24 litre	BPB	0471
2	Inspection plug	BPB	0243
3	Inspection plug seal	BPB	0502
4	Delivery hose - 300mm	BPB	1087
5	Non return valve	BPB	1086
6	Relief valve	BPB	1084
7	1/4 MFF tee	BPB	1109
8	Drain tap	BPB	1138
9	Drain tap tube & clamp	BPB	1138
10	Siphon tube	BPB	0536
11	Pressure switch	BPB	1074
12	1/4 x 1/4 connector	BPB	1078
13	On/off valve	BPB	1079
14	Filter regulator unit	BPB	1080
15	40mm pressure gauge	BPB	1077
16	50mm pressure gauge	BPB	1081
17	1/4 extension piece	BPB	0152
18	Wheel kit	BPB	0157

BB24V

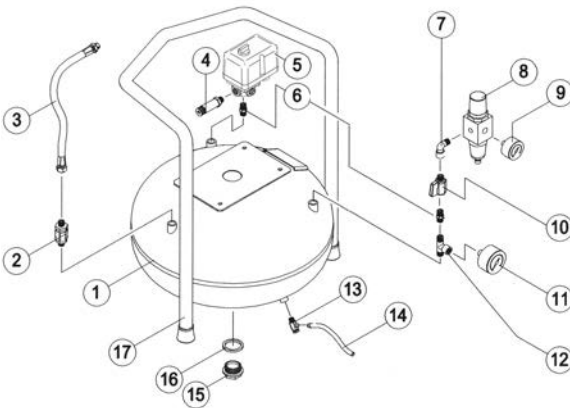

Ref No.	Description		Part no.
1	Air receiver - 24 litre verticle	BPB	0472
2	Non return valve	BPB	1086
3	Delivery hose - 200mm	BPB	1102
4	Relief valve	BPB	1084
5	Pressure switch	BPB	1074
6	1/4 x 1/4 connector	BPB	1078
7	1/4 MF elbow	BPB	1139
8	Filter regulator unit	BPB	1080
9	40mm pressure gauge	BPB	1077
10	On/off valve	BPB	1079
11	50mm pressure gauge	BPB	1081
12	1/4 MFF tee	BPB	1109
13	Drain tap	BPB	1138
14	Drain tap tube & clamp	BPB	1138
15	Inspection plug	BPB	0243
16	Inspection plug seal	BPB	0502
17	Rubber foot	BPB	0247

On auto drain machines the pressure switch part number is BPB0550 and the unloader valve is part number BPB1205.

BB24D

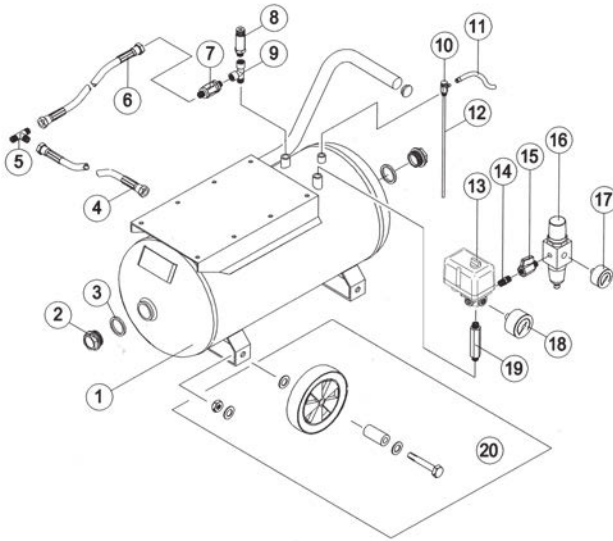

Ref No.	Description		Part no.
1	Air receiver - 24 litre	BPB	0473
2	Inspection plug	BPB	0243
3	Inspection plug seal	BPB	0502
4	Delivery hose - 200mm	BPB	1102
5	1/4 tee	BPB	0497
6	Delivery hose - 200mm	BPB	1102
7	Non return valve	BPB	1086
8	Relief valve	BPB	1084
9	1/4 MFF tee	BPB	1109
10	Drain tap	BPB	1138
11	Drain tap tube & clamp	BPB	1138
12	Siphon tube	BPB	0536
13	Pressure switch	BPB	1074
14	1/4 x 1/4 connector	BPB	1078
15	On/off valve	BPB	1079
16	Filter regulator unit	BPB	1080
17	40mm pressure gauge	BPB	1077
18	50mm pressure gauge	BPB	1081
19	1/4 extension piece	BPB	0152
20	Wheel kit	BPB	0157

BB50D

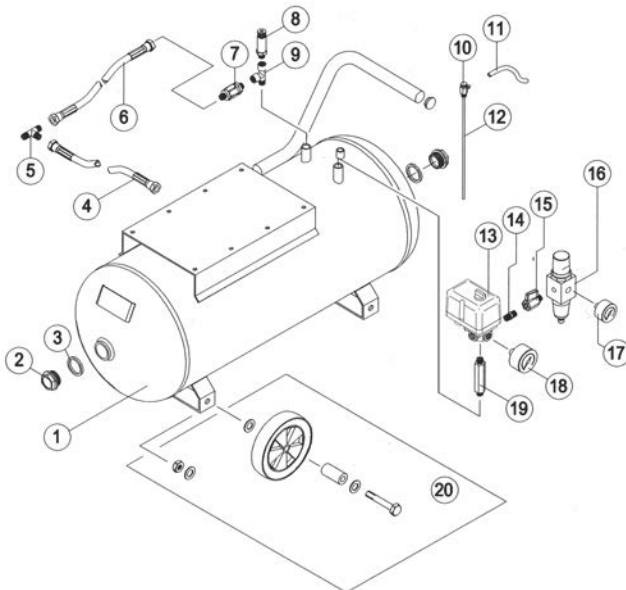

Ref No.	Description		Part no.
1	Air receiver - 50 litre	BPB	0474
2	Inspection plug	BPB	0243
3	Inspection plug seal	BPB	0502
4	Delivery hose - 200mm	BPB	1102
5	1/4 tee	BPB	0497
6	Delivery hose - 300mm	BPB	1087
7	Non return valve	BPB	1086
8	Relief valve	BPB	1084
9	1/4 MFF tee	BPB	1109
10	Drain tap	BPB	1138
11	Drain tap tube & clamp	BPB	1138
12	Siphon tube	BPB	0034
13	Pressure switch	BPB	1074
14	1/4 x 1/4 connector	BPB	1078
15	On/off valve	BPB	1079
16	Filter regulator unit	BPB	1080
17	40mm pressure gauge	BPB	1077
18	50mm pressure gauge	BPB	1081
19	1/4 extension piece	BPB	0152
20	Wheel kit	BPB	0157

On auto drain machines the pressure switch part number is BPB0550 and the unloader valve is part number BPB1205.



Fig 1

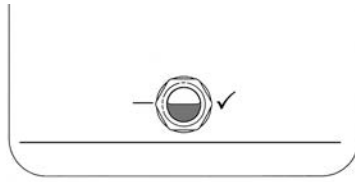

Fig 2

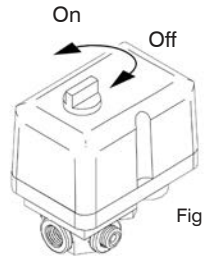

Fig 3

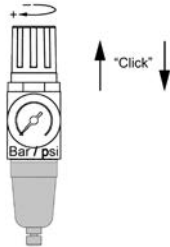

Fig 4



Fig 5

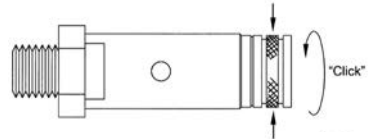

Fig 6

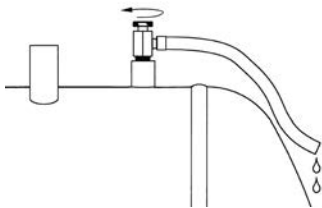

Fig 7: Top mounted drain

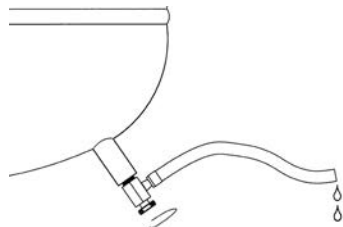

Fig 8: Bottom mounted drain

Technical Specification & Wiring diagram

Budget Pump Specification		
Motor Kw / Hp	0.37 / 0.5	0.44 / 0.5
Voltage	220/240	110
Frequency Hz	50	60
Amps	2.4	6
Watts	340	446
Displacement l/min	50	60

