

# BV300S-D

## Extraction Units



### Extraction Unit for Aerosols, Airbrushes

and more .

Contains, filters and extracts for a cleaner, healthier working environment for the hobbyist, modeller and arts and craft enthusiast.

### Applications include filtration and removal of:

Aerosol paints, lacquers, adhesives (glue booth for Spray Mount). and airbrush overspray. Solder fume, general solvent vapours and gases extracted to atmosphere. Filtration of grinding dusts, general particulates and powders etc



Demonstrating adequate control of the risks to the health of employees, students and the general public, from dusts, powders, mists, fumes and vapours is the fundamental requirement of the Control of Substances Hazardous to Health (COSHH) regulations 2002 and 2004.

[www.benchvent.com](http://www.benchvent.com)

# BenchVent Extraction Cabinets

NOTE: This unit exhausts air via flexi-duct to atmosphere.

For a cleaner, healthier working environment.

## Description

Steel construction finished in dove grey – plastic replaceable spray/fume shield – particulate filter – centrifugal blower, external rotor motor type brushless, UL, VDE and CSA approved - sealed electrical wiring and switch, downstream of filter. Flexi-duct 2 metres x 100mm dia. – carry handle.

## Operation:

**All BenchVent filtration and extraction systems carry a lifetime warranty.**

They are quiet in operation and is assembled in seconds. Place on a desk, bench or trolley and then plug in and switch on. You can fix the plexi-duct to a standard domestic vent or through a partially open window, making it very portable.

This unit can be used in two positions.

**Horizontal position** – for Spray Mount, aerosol lacquers and fixatives etc. applied to artwork placed onto the filter. Accommodates artwork up to A3 size.

**Vertical position** – For model sprays and airbrush use – light grinding particles (not sparking) – solder fume ex-traction and general solvent and gas extraction.

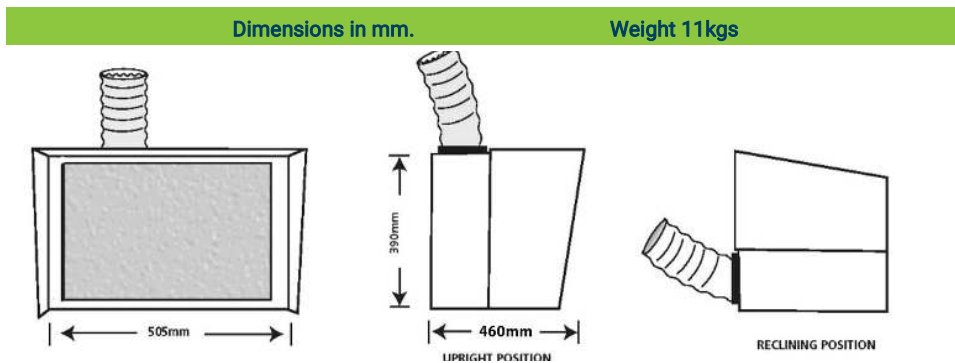

## Filtration

The particulate (intake) filter is a three stage graduated fibre filter with a high 'dust' holding capacity for long life. Filtration to 5 micron particles. NB: Spray particulate sizes vary from 10 to 20 microns. The carbon impregnated fibre filter (behind intake) assists in the reduction of solvent odours.

**Through the process of filtration, adsorption and dilution, operator exposure to concentrations of potentially hazardous substances is vastly reduced.**

## Specification

Model Number	Fan Motor* Spec	Air Volume At Free Air	Ave. Air Velocity At Filter Face	Ave. Air Velocity At Hood Face	Noise Level LAeq dB(A)
BV300S-D	230V 50Hz 105W	355m <sup>3</sup> /hr	0.6m/sec	0.55m/sec	60

\*115v 60Hz available on request

This unit is designed for studio / workshop cleanliness and for immediate operator protection from concentrations of airborne contaminants. They are not recommended for continual usage, i.e. production applications, particularly in confined and/or badly ventilated areas.

See extraction cabinets BV200H-D and BV100H-D for total solvent odour and gas extraction, or BV660H-C or BV930H-C filtration cabinets for higher specification filtration.

Please contact BenchVent for advice on the choice of machine for any given situation.

T: 01423 790039

E: [enquiries@benchvent.com](mailto:enquiries@benchvent.com)

W: [www.benchvent.com](http://www.benchvent.com)

BenchVent, Unit 1 Levens Hall Park, Lund Lane, Killinghall, Harrogate, North Yorkshire, HG3 2BG

Company No: 03217859 Registered office: Widespread Solutions Ltd, Unit 1 Levens Hall Park, Lund Lane, Killinghall, Harrogate, North Yorkshire, HG3 2BG

BenchVent is a trading style of Widespread Solutions Ltd

We go to great lengths to ensure accuracy in our literature, however we cannot be held responsible for errors or omissions. Information is given for guidance only and we reserve the right to alter specification.