

BV260S

Glue Booth

BenchVent
The Bench Ventilation Company

Booths for Glues, Aerosols, Airbrushes and more

Contain and filter for a cleaner, healthier working environment within art, graphics, hobby, modelling and crafts.

Applications include filtration of:

Aerosol adhesives (glue booths for Spray Mount), aerosol lacquers and fixatives and airbrush sprays applied to artwork up to B3 size (353 x 500 mm).

Recommended application:

Craft, hobby, model aerosol and airbrush paints, solders, light grinding particles and dusts, cleaning solvents, etc.

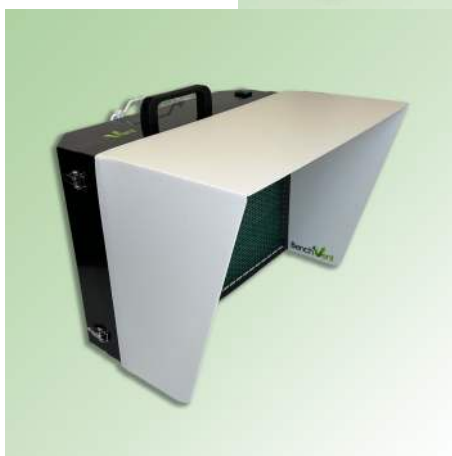

Demonstrating adequate control of the risks to the health of employees, students and the general public, from dusts, powders, mists, fumes and vapours is the fundamental requirement of the Control of Substances Hazardous to Health (COSHH) regulations 2002 and 2004.

www.benchvent.com

BenchVent Air Filtration Spray Booth

NOTE: These units are recirculatory; i.e. filtered air is exhausted back into the workplace

For a cleaner, healthier working environment.

Description:

Steel construction finished in black—replaceable spray/fume shield—back stand/carry handle—particulate filter—carbon impregnated charcoal fibre filter—2x axial fans, external rotor motor type brushless., UL VDE and CSA approved—sealed electrical wiring and switch down stream of **Filters:** Particulate + Carbon Impregnated Fibre Filter

Operation:

All WS filtration and extraction systems carry a lifetime warranty, are quiet in operation and can be assembled in seconds. Place onto a desk, bench or trolley and then simply plug in and switch on.

These units can be used in two positions.

Reclining position (on back-stand) – For Spray Mount, aerosol lacquers and fixatives etc. applied to artwork placed onto the filter. BV260S accommodates artwork up to B3.

Upright position – For model sprays and airbrush use – light grinding particles – solder fume displacement – general solvent dilution etc. onto the hood base for spraying, cleaning, sanding etc.

Dimensions in mm

Weight 19kgs

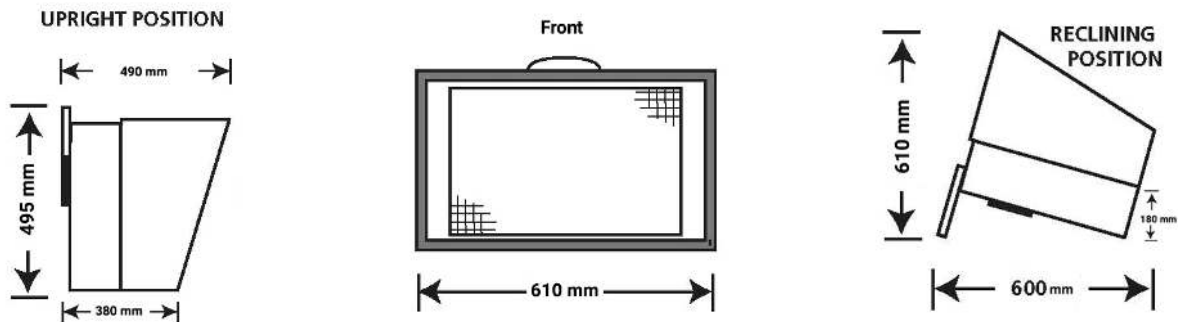

Specification

Model Number	Fan Motor* Spec	Air Volume At Free Air	Ave. Air Velocity At Filter Face	Noise Level LAeq dB(A)
BV260S	230V 50Hz 80W	610m ³ /hr	0.6m/sec	61

Filtration

The particulate (intake) filter is a three stage graduated fibre filter with a high 'dust' holding capacity for long life. Filtration to 5 micron particles. NB: Spray particulate sizes vary from 10 to 20 microns. The carbon impregnated fibre filter (behind intake) assists in the reduction of solvent odours.

Through the process of filtration, adsorption and dilution, operator exposure to concentrations of potentially hazardous substances is vastly reduced.

These units are designed as predominantly 'spray traps' for studio or workshop air cleanliness and for immediate operator protection of airborne contaminants. They are not recommended for continual usage, such as in production applications, particularly in confined and/or badly ventilated areas.

See extraction cabinets **BV300S-D**, **BV200H-D** and **BV100H-D** for total solvent odour and gas extraction, or **BV660H-C** or **BV930H-C** filtration cabinets for higher specification filtration. Please contact BenchVent for advice on the choice of machine for any given situation.

T: 01423 790039

E: enquiries@benchvent.com

W: www.benchvent.com

BenchVent, Unit 1 Levens Hall Park, Lund Lane, Killinghall, Harrogate, North Yorkshire. HG3 2BG

Company No: 03217859 Registered office: Widespread Solutions Ltd, Unit 1 Levens Hall Park, Lund Lane, Killinghall, Harrogate, North Yorkshire. HG3 2BG

BenchVent is a trading style of Widespread Solutions Ltd